

Letter from the President



David Wildberger
President

To all that may not yet be aware, Evergreen Transport has partnered with U.S. Oil to purchase CNG (com-

pressed natural gas) at our Calera terminal. U.S. Oil is currently in the process of installing a compressor compound and two quick-fill fueling dispensers, which should be completed by April 1, 2014. We are anticipating going live, and begin fueling on April 1, if not before the April 1 deadline. We will also have part of the station pre-plumbed for two additional quick-fill fuel dispensers to accommodate fueling for any additional CNG tractors.

We currently have on order 12 new 2014 Mack day cabs powered by the Cummins Westport's new 12-liter 400 HP (ISX12 G) engines. Mack has estimated these engines will get approximately 5.8 to 6 miles per gallon. The fuel storage and fuel delivery system is manufactured by

Agility Fuel Systems, which is headquartered in Santa Ana, CA. The actual tanks will be assembled at their assembly facility located in Anniston, AL. There will be two saddled frame-mounted fuel tanks, each with a 45-gallon capacity. The 12 new units will be delivered in March 2014, and put into immediate service on our dedicated rock haul for Lhoist.

In our next edition I will explain why Evergreen Transport is moving toward clean energy and the positive economic impact it will have on our company. Currently, we are the 1st Alabama based truckload carrier that is converting a portion of our fleet from diesel to natural gas.

I wish our Evergreen family a very safe and wonderful Holiday Season.

Tips to Start Planning Next Year's Tax Return

For most taxpayers, the tax deadline has passed. But planning for next year can start now. The IRS reminds taxpayers that being organized and planning ahead can save time and money in 2014. Here are six things you can do now to make next April 15 easier.

- 1. Adjust your withholding.** Each year, millions of American workers have far more taxes withheld from their pay than is required. Now is a good time to review your withholding to make the taxes withheld from your pay closer to the taxes you'll owe for this year. This is especially true if you normally get a large refund and you would like more money in your paycheck. If you owed tax when you filed, you may need to increase the federal income tax withheld from your wages. Use the IRS Withholding Calculator at IRS.gov to complete a new Form W-4, Employee's Withholding Allowance Certificate.
- 2. Store your return in a safe place.** Put your 2012 tax return and supporting documents somewhere safe. If you need to refer to your return in the future, you'll know where to find it.

For example, you may need a copy of your return when applying for a home loan or financial aid. You can also use it as a helpful guide for next year's return.

- 3. Organize your records.** Establish one location where everyone in your household can put tax-related records during the year. This will avoid a scramble for misplaced mileage logs or charity receipts come tax time.
- 4. Shop for a tax professional.** If you use a tax professional to help you with tax planning, start your search now. You'll have more time when you're not up against a deadline or anxious to receive your tax refund. Choose a tax professional wisely. You're ultimately responsible for the accuracy of your own return regardless of who prepares it. Find tips for choosing a preparer at IRS.gov.
- 5. Consider itemizing deductions.** If you usually claim a standard deduction, you may be able to reduce your taxes if you item-

TaxTips, continued on page 3

Calera Terminal with Manager Jason Bentley

We hope everyone had a blessed Christmas and we are looking forward to a great New Year fulfilled with abundance of freight and opportunities. Calera's freight as well as Leeds freight has been sporadic over the last several months as some of our regular hauls have been slowed or stopped due to yearly outages, holidays and the weather conditions. We anticipate business to start trending upward and we look forward working with all of our customers in the upcoming year. Our 24/7 operations at the Calera terminal are ready to serve

you. Drivers please remember to communicate with dispatch often and especially when there may be a delay causing your delivery to be late. As a wise man said "Real Time" communications always keeps everyone informed. We all have been working to improve our communication skills from prompted phone calls to replies to emails.

I know we all have our own New Year's resolutions, but let's set one for **Evergreen Transport** as a team. "Stay positive in all situations."

Mobile Terminal with Manager Rick Mangrum

It's been a quiet quarter for the Mobile terminal; most of our shippers and customers are reducing their inventories and spending toward the end of the year. As we all know around the holiday season it slows down. We did pick up some additional end dump business from JDS Construction and Hosea O. Weaver. JDS Construction has signed a contract to move 370,000 yards of aggregate material, and is currently bidding on another 300,000 yards for the new Costco store ground project. JDS has awarded Evergreen the haul and look forward to having a long lasting partnership.

We have several jobs starting up the 1st quarter of 2014. Holcim was awarded the Santa Rosa County bridge project in Florida. We will be taking type I/II cement to Holcim Midfield, AL and returning with slag cement to Holcim Theodore, AL. Holcim will use the slag material to produce a blended cement product for the Florida bridge project. The project is expected to go through the end of 2015. Our Cement Spreader Bar customers are predicting an outstanding year for 2014. They are telling me that between new Government and State Highway funding and Oil Rig job site projects will increase their profits tremendously. This will cause a domino effect for everyone to have a more prosperous year. When a shipper or customer asks me about our company, I always reply by saying, "Evergreen Transport is a dedicated carrier who strives in

moving our customer's product swiftly but safely and on time."

Safety tip for drivers

According to DOT rules and regulations all flatbed loads are to be secured with 2 straps on the first two pallets in front of the trailer, and 2 straps on the last two pallets. Also all straps should be under the tarps and inside the side rails. Make sure you have the proper amount of straps and bungee cords before leaving the terminal.

Possessing the necessary equipment to secure your load properly will reduce the wear on our tarps helps prevent a possible load shift or loss when involved in an accident. DOT will give you a citation if you do not properly secure your load.

FUEL REMINDER

Fuel and the Terminal Locations should be first priority.



Then all Road Fuel Purchases are at Pilot and Flying J Truck Stops only.

Jackson Terminal with Manager Larry Yeargan

From the Jackson terminal to all we wish you a very Merry Christmas and Happy New Year.

I want to take this time to send a thank you from our drivers and other employees here to David and those involved in providing dinner for us here in Jackson and we all look forward to an even more prosperous 2014.

The last couple of months have been slow for us here in Jackson due to Powersouth burning natural gas instead of Coal. This is a decision they make from time to time when gas is cheaper than their Coal prices and power demands are down but Mike has informed us they are bringing up one of

their units in the next few days that was scheduled to be down until after the first of the new year. This is good news and will increase revenue for both Mobile and their Ash haul and for Jackson with increases in Limestone and Gypsum moves. Hate to say it but, the colder the weather which increases power demands the more Powersouth moves from natural gas back to Coal so get your coats on and pray for cold weather, real cold weather.

Again, hope everyone has a very Merry Christmas and Happy New Year.

Joan Davis Accounting Supervisor

Joan started working for Mr. Poole in 1975 when he owned Poole Trucklines Inc. She started in the Trip Lease Department and later transferred to Billing and Rates. Back then trucking was regulated and there were no brokerage so a carrier had to put signs on his truck showing that he was temporarily leased to another carrier to haul their freight. Rates were kept in regulated Tariffs and were updated constantly so you have to keep abreast of all updates. There was a lot of paperwork to be filled out as information in computers was entered by a key punch operator instead of a user. Very time consuming.

She left Poole in April 19, 1989, drove across the interstate to work for Evergreen Transportation Inc. starting in the Billing Department, and later becoming Billing Supervisor and Collections Manager. She was with Evergreen for a total of 21 years.

When Mr. Poole formed Evergreen Transport LLC in 2010 she did not even have to drive anywhere just kept coming to

the same location and handled a lot of the information during the transfer for Mr. Poole and Mr. Wildberger. She is in charge of Contract updating, Drivers Payroll, Collection Manager, and Billing Supervisor.

She has been married for 43 years and has 2 sons, Chris and Drew, and 5 Grandchildren which she is more than happy to show you pictures of. Drew was fortunately enough to play for the University of Alabama and was a member of 2009 National Championship Team.

Her hobbies are cattle farming and ALABAMA FOOTBALL!! ROLL TIDE!!



Joan Davis



Tim Trivette

Tim Trivette New Safety Supervisor

Evergreen Transport, LLC is proud to welcome Tim Trivette as our new Safety Supervisor for the Calera, AL terminal. Tim has over 16 years experience in the transportation industry.

Tim's background includes, but is not limited to, Safety, Operations, Training, DOT, CSA, and Personnel.

Tim also brings a lot of enthusiasm and excitement everywhere he goes.

"In order to be successful, we all need to understand and practice truck safety. That means more than just learning safe driving techniques — safety should be the foundation of one's trucking career. And no matter whether you're an industry veteran or just climbing behind the wheel, it never hurts to review the basics," Trivette reflects.

We are proud to have him as a part of the Evergreen Team!

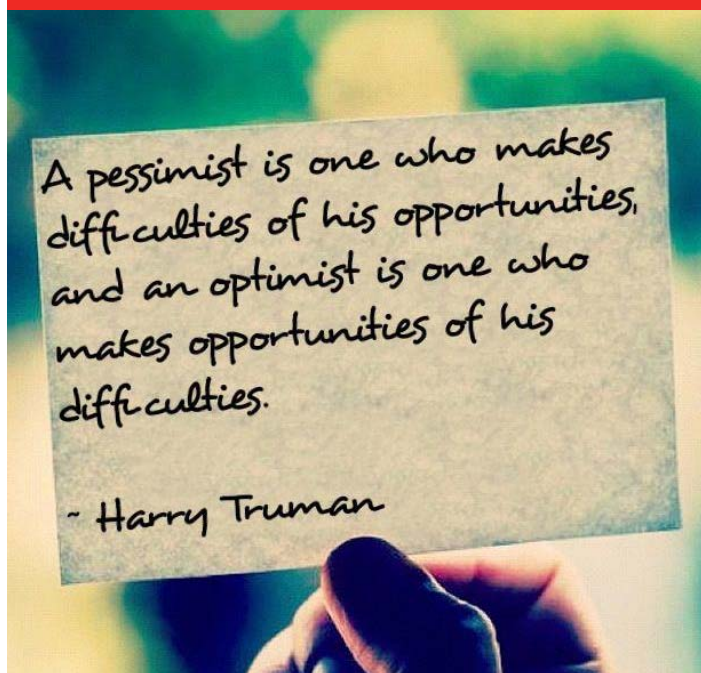

Tax Tips, continued from page 1

ize deductions instead. If your itemized deductions typically fall just below your standard deduction, you can 'bundle' your deductions. For example, an early or extra mortgage payment or property tax payment, or a planned donation to charity could equal some tax savings. See the Schedule A, Itemized Deductions, instructions for the list of items you can deduct. Planning an approach now that works best for you can pay off at tax time next year.

6. Keep up with changes. Find out about tax law changes, helpful tips and IRS announcements all year by subscribing to IRS Tax Tips through IRS.gov or IRS2Go, the mobile app from the IRS. The IRS issues tips regularly during the summer and tax filing season.

You can find forms and publications at IRS.gov or order them by calling 800-TAX-FORM (800-829-3676).

IRS Tax Tip 2013-62, April 24, 2013

Evergreen Teams Up with AL Troopers

On November 6, 2013, Evergreen Transport driver George Jones joined forces with the Alabama State Troopers to target aggressive driving around tractor trailers. The Ticketing Aggressive Cars and Trucks (TACT) program is a high visibility enforcement program that uses communication, enforcement, and evaluation activities to reduce CMV-related crashes, fatalities, and injuries.

This is the third time that Evergreen Transport and the Alabama State Troopers have teamed up in an effort to identify and ticket aggressive drivers on our roadways. A Trooper rides along with George for a day and communicates any aggressive drivers to fellow troopers posted along the route. The Troopers stop that vehicle and have a little "fellowship" with the aggressive driver.

Evergreen Transport is proud to be an active participant in the

TACT Program. We must never let our guard down in making our highways safe for all travelers.



Meet Wayne (Chip) Stallworth



Chip started trucking in 1987 and came to work for Evergreen Transportation Inc. in February of 1989. He started on a dedicated run from Calera AL to Cantonment FL and continued that until they changed over from running printing paper to running stock paper. This caused the decline in the number of lime loads needed daily. Chip continued in trucking when Evergreen Transportation closed down to

Evergreen Transport LLC opening up. He had 21 years with

Evergreen Transportation and now 4 years with Evergreen Transport LLC. He is still running lime out of Calera and occasionally will run plastic pellets out of Pensacola when there is excess freight. He became a member of the Million Mile Club with Evergreen Transportation Inc. with over 1.25 million miles.

Chip has been married to his wife Deborah for 14 years. He has 4 children, Wayne Jr., April, Raven, and Denise. He is the proud Grandfather of 11 Grandchildren.

Chip has coached in youth football and basketball and refereed high school football. He still occasionally referees a few games when he is not driving. He did play softball for Booker T. Washington and they won many championships in the area. He is also an avid AUBURN fan. WAR EAGLE!!!!!!

Flash Back: Trip to Las Vegas 1983



Do You Recognize Anyone?



Meet Randy Dillard

Randy Dillard started with Evergreen Transportation Inc. in 1988 hauling cement and lime out of the Calera/Birmingham area and continued to stay with Evergreen Transport LLC when we opened up in 2010. He earned his million mile award while with Evergreen and was a member of the President Club at that time.

He is the single parent of an 18 year old son.

Meet the Evergreen Terminal Employees



Robert Phillips, Arnold Stinson, Allen Padgett



Deborah Kendrick, Teresa Covin, Joan Davis



**Back: Matt Stanford, Gary Wingard, Charles Colvin.
Front: Herbert Holder, Dustin Odom, Bobby Colvin**



Kevin Bowman, Kim Hardin, Chuck Talbot



Stephanie Davis and Gil Davison



**Elaine Booker, Sharon Cook, Karla Ward, Debbie Grimes,
and Randy Watson**

Winter Driving Tips

Get Rest

- Fatigue seems to be a way of life for truckers, especially for over the road (OTR) drivers. Long days, short nights, unfamiliar surroundings, not always the best food available -- all can weigh in and make you tired. As much as it is within your ability, make sure that you get adequate rest

Stay Right

- Avoid the temptation to use the left lane other than for passing. In fact, in some states as well as on some interstate highways, tractor trailers are not permitted to use the left lane at all. By moving over, you'll allow faster (and impatient) passenger vehicles to pull away from you. It's a safety hazard when they're tailgating or riding right next to you.

Road Conditions

- Slippery, icy or otherwise wet roads present a safety hazard to truckers as well as to everyone else on the road. Stop times take longer, maneuvering becomes more difficult and visibility is reduced. Potholes, road work and uneven pavement can also make it hard for tractor-trailer drivers to control multiple tons of freight. Slow down when less than ideal conditions are present.

Situational Awareness

- Driving for long periods of time without rest can bring on boredom and lower the defenses of any driver. But losing awareness of your driving situation can be harmful, perhaps deadly. Always leave plenty of space between you and the vehicle in front of you, be aware of cars you cannot see in your rear mirrors and stay in touch with other drivers on your radio.

11 Steps to a Clean Vehicle Inspection

CSA (Compliance, Safety and Accountability) is a new motor carrier program in effect that changes the way truck fleets and drivers are measured for safety performance. Safety accountability falls heavily on truck drivers under the CSA. Now, every driver violation and vehicle violation will not only be counted toward the motor carrier's safety score but may also become part of the driver's safety history.

Driver profiles will now be tracked in a database call the Driver Safety Measurement System (DSMS) which evaluates drivers' roadside performance over a three year period. This following handout will help drivers to avoid equipment violations on roadside inspections and receive a "clean vehicle" inspection.

Step 1 - Engine

Look for leaks, belts, hoses, steering linkage, leaf springs, hangers, shocks, inside and outside of tires and rims, lugs, wheel seals, brake drums

Steps 2 & 4 - Sides of cab

Mirrors, battery box, fuel tank, turn signals, reflectors

Step 3 - Front of cab

Clearance lights, head lights, 4 way, license plate, wipers, windshield, registration, inspection

Step 5 - Rear of tractor

Airlines, electrical lines, cat walk, exhaust, muffler

Step 6 & 10 - Coupling system of tractor

Fifth wheel components, drive tires, rims, lugs, mud flaps, king pin, lights - tail, stop, turn

Step 7 & 9 - Sides of trailer/cargo body

Lights, reflectors, landing gear, suspension, airlines, body mounts, tires, rims, lugs, brakes, wheel seals, exhaust

Step 8 - Rear of truck/trailer

Taillights, stop lights, turn lights, mud flaps, license plate and light, ICC bumper, door latch

Step 11- Inside of cab

Horns, extinguisher, reflective triangles, seatbelt, registration, paperwork

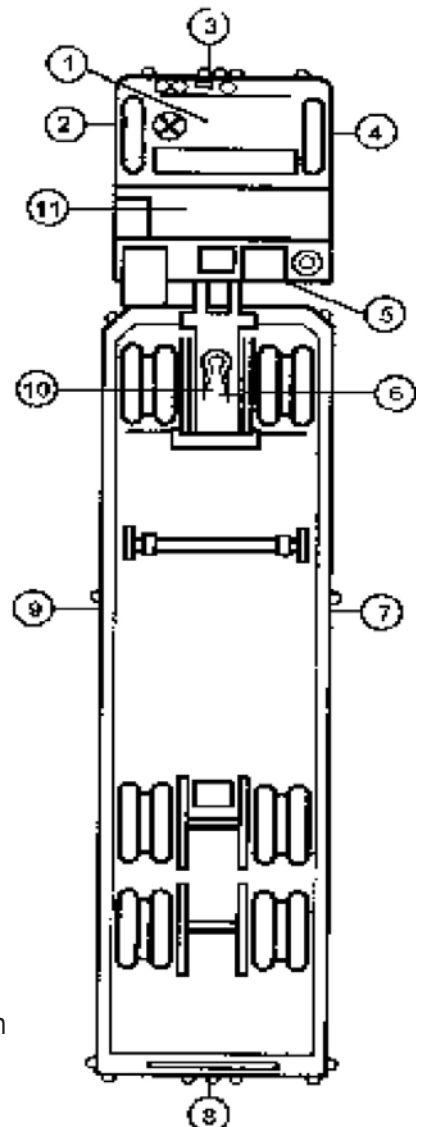

Welcome Aboard - October, November, December

TRIVETTE, TIMOTHY D
SWEENEY, SHAWN P.
BLACKMON, MARIO D.
CAIN, MICHAEL
BENTON, WILLIAM M.
JOHN M BLANKENSHIP

BEARDEN, THOMAS W.
WOODS, JAMES
SMITHERMAN, JAMES
JAMES L STRICKLAND
GILBERT, RORY K.
KEY, PHILLIP A.

DAVIS III, GABE
WAY, WENDELL C.
LANE, JENNIFER B.
MCDANIEL, DANIEL R.
DIXON, GREGORY

Anniversaries

4 Year

GEORGE O JONES
ROBERT R. PHILLIPS
WAYNE D. STALLWORTH
BOB R. DILLARD
JERRY CARTER
HOWARD K CARDEN
CHARLES H. HUGHES
HERBERT F. HARMER
EDDIE J. BETTIS
STEVE A. TYUS
FONDELL SMITH
BEN C. JAMES
PHILLIP W. EGGLE
JOHNNY R. RATLIFF
JOE L. WASHINGTON
PAUL D. HENSON
ROGER L. CATON
BEN E. POWELL
WILLIE J. BATCH

ERIC B. HARRIS
JAMES LONGACRE
DANNIE L. CHILDERS
GERALD W. HAMRAC
JESSE SULLIVAN
JAMES D. MCNEIL
MICHAEL SCOTT
CHRISTOPHER DAVENPORT
EDWARD S. BENSON
EDWARD LANEAU
DAVID C. CROW
RONALD R. SCOTT
HARRY J. VERRETT
GARY M. DAGG
HERCIAL L. COLVARD
KEVIN L. BOWMAN
DAVID J. WILDBERGER, SR.
RONALD K. KENT
ARNOLD STINSON

JOAN B. DAVIS
JOHN R. DYKES, SR.
SHARON T. COOK
CHARLES E. TALBOT
CHARLES E. COLVIN
BOBBY R. COLVIN
HERBERT M. HOLDER
DEBORAH S KENDRICK
FRED L. WEAVER
MELVIN D. ETHEREDGE
ELLON G. HAYES
STEPHANIE C. DAVIS
CHARLES WILDER
KEVIN L. BOWMAN
RODNEY A. PADGETT
DONALD C. HAYES
FRANK MILLER III
TERESA B. COVIN
ELAINE BOOKER

JAMES E AMOS
LINDA BAISCH
JASON A BENTLEY
THOMAS R WATSON, JR
DEBRA B. GRIMES
MARVIN B SASHINGTON
JENNIFER H HUEBNER
CYNTHIA D BLALACK
REAGAN L YEARGAN
KENNY L BAKER
PHILLIPS, ROBERT R
MICHAEL C. CHRISTIAN
ROBERT O PHILLIPS
JAMES E ASHBEE
JIM H SPENCE JR
GREGORY E. WILLIAMS
OSCAR HARRINGTON
RUDOLPH J MANGRUM

3 Year

GARY HOLSOMBACK
BRIAN K. BEARDEN
JAMES A HOLSTEIN
JOE L. JOHNSON
MICHAEL S. MEEHAN
EUGENE ROWSER JR
JAMES E. JACKSON
WESLEY S. JOINER

2 Year

JONATHAN C SANDERS
REGINALD D. HATCHER
TONY M. HINMAN
SKIP WOMACK
KARLA B. WARD
CHARLES W. RINEHART
KEITH VARDAMAN

1 Year

JOSEPH R. HENDERSON
BRETT A. FLYNT
BRANDON S. EVANS
MICHAEL E. GENTRY
KENNETH R ANDERSON
DEMETAURIS T. WONGUS

January, February, March Birthdays

January

REGINALD D. HATCHER	1
SHAWN P. SWEENEY	2
VINCENT BURNETT	3
ELLON G. HAYES	4
KENNETH CASH	5
ARTHUR JONES III	5
DERRICK W. JOHNSON	6
TEARS Q. RICHARDSON	11
CLARENCE SEYFRIED	11
CRAIG D. BICE	12
SAMMY E. JACKSON	14
DOVER M. EDWARDS III	14
JAMES LONGACRE	16
AARON HADLEY	17
DEBORAH S. KENDRICK	19
DAVID C. CROW	20
GREGORY DIXON	25
WILLIAM P. TRAYWICK	29

February

BILLY D. RICE	2
LYNN WILLIAMS	4
MICHAEL SCOTT	7
JAMES E. JACKSON	7
ARTHUR M. LEE JR	7
RAPHAEL PETTIS	7
WILLIAM M. BENTON	8
HOWARD K. CARDEN	9
DARRIUS A. CRAIG	9
DANNY E. HOLSTINE	12
CHARLES H. HUGHES	19
GERALD W. HAMRAC	20
DAWN P. LACENERE	21
JAMES A GARRETT	22
JONATHAN OLDS	23
JAMES B. JONES	27
ZACHARIAH L. JONES	28

March

PHILLIP A. KEY	3
EDWARD R. RUEMMLER	3
RONALD E WOODS JR	4
WAYNE D. STALLWORTH	8
ROBERT W. FRALICK	9
JOE L. JOHNSON	11
ANDREW J. JOHNSON JR	15
ROBERT A. SNIDER	16
DARRIUS L. JACKSON	17
BEN E. POWELL	18
DOUG CLECKLER	20
JOSHUA R. AUTREY	20
GABE DAVIS III	20
JENNIFER H. HUEBNER	22
DEBRA B. GRIMES	23
CEDRIC B. MENEFEE	24
JERRY CARTER	25
MACK A. MIXON	25
KENNY L. BAKER	26
MARVIN B. SASHINGTON	27
JOHN E. CARTER	28
CALVIN WRIGHT	29
DANNIE L. CHILDERS	31